

# BRONZE CRAFT

## DEFENDER HINGES

### INLINE MOUNTING

*A smooth long-life performance hinge.*

- Tested to AAMA 904.1 standard.
- Ideal for aluminum, vinyl and wood applications.
- Wide angle opening for easy clean.
- Most sizes readily available from stock.
- Casement hinges are fitted with a unique plastic raiser block which guarantees the surest fit.



## WHY USE AN ASYMMETRIC END CAP?

*This proven asymmetric locating system on the Defender hinge uses the full width of the vent arm to ensure accurate collection of the vent.*



*This means that the end point on the vent arm is collected earlier than on conventional symmetrical hinges and prevents the natural window geometry from forcing the vent point outside the end cap into a failed position.*



*This then ensures that the end point is firmly directed towards the closed position. The unique thermoplastic end point and cap are self-lubricating providing smoother operation and longer life.*



*The positive fit of the Defender end point in the end cap helps to provide a weather-tight seal for the window.*



• NOTE: THESE PRODUCTS ARE AVAILABLE BY SPECIAL ORDER. PLEASE CONTACT OUR SALES OFFICE FOR PRICING AND DELIVERY SCHEDULES.

**PROJECTED**

Part Number	Nominal Size	Opening Angle	Max. Weight	Vent Max. Height	Vent Max. Width	Min. Pack
851-001-8646	6" (159mm)	50°	22# (10kg)	11.8" (300mm)	47.25" (1200mm)	50 pr
•851-002-8646	8" (209mm)	50°	26.4# (12kg)	13.75" (350mm)	47.25" (1200mm)	50 pr
851-003-8646	10" (259mm)	80°	35.2# (16kg)	15.75" (400mm)	47.25" (1200mm)	50 pr.
851-004-8646	12" (310mm)	80°	44.1# (20kg)	21.65" (550mm)	47.25" (1200mm)	50 pr
851-005-8646	16" (412mm)	80°	46.3# (21kg)	29.5" (750mm)	47.25" (1200mm)	25 pr
851-006-8646	20" (512mm)	50°	52.9# (24kg)	39.38" (1000mm)	39.38" (1000mm)	25 pr
	or alternatively			33.46" (850mm)	47.25" (1200mm)	25 pr
851-007-8646	24" (614mm) Heavy Duty	37.5°	77.1# (35kg)	47.25" (1200mm)	47.25" (1200mm)	25 pr

**CASEMENT**

852-001-8646	12" (310mm)	60°	48.5# (22kg)	51.18" (1300mm)	23.62" (600mm)	25 pr
•852-002-8646	Same as above except countersunk for screws					25 pr
852-003-8646	16" Heavy Duty	60°	52.9# (24kg)	51.18" (1300mm)	27.56" (700mm)	25 pr.

**RESTRICTOR STAY**

880-001-8646	6" (155mm)					50 pr
880-002-8646	10" (259mm)					25 pr

NOTE: WE RESERVE THE RIGHT TO ALTER SPECIFICATIONS IN FURTHERING OUR POLICY OF CONTINUAL PRODUCT IMPROVEMENT.

IMPORTANT: UNDER NO CIRCUMSTANCES SHOULD THE SIZE OR WEIGHT OF THE WINDOW EXCEED THE STATED CAPACITY OF THE FRICTION HINGE USED.

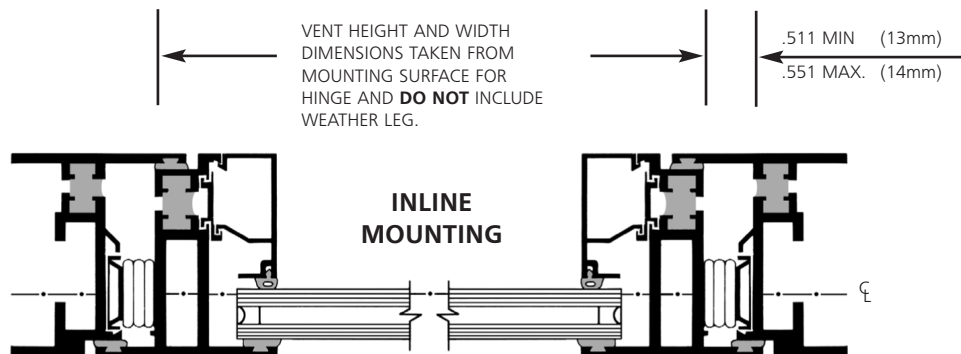

CLEARANCES SHOWN ARE COMMON TO BOTH THE PROJECTED AND CASEMENT APPLICATION.

**MATERIALS**

**HINGES:**

Prime Stainless Steel Type 430

**RIVETS:**

Type 430 Stainless Steel

**END CAPS, SLIDERS & GUIDES:**

Thermoplastic Resin

**SLIDE MECHANISM:**

Incorporates an adjustable screw bearing onto a thermoplastic friction pad

**WASHERS:**

Thermoplastic, place between all link pivot points



**Innovation in Window Hardware**

Patent Nos.  
UK 2047309, UK 2081803  
UK 2081804, UK 2133074  
UK 2233458, Patents applied for  
UK 8429390.

**DISTRIBUTED BY:**

**BRONZE CRAFT**

COPYRIGHT © 2004

www.bronzecraft.com

37 WILL ST., P.O. BOX 788  
NASHUA, NH 03061-0788  
800-488-7747

TEL: 603-883-7747 FAX: 603-883-0222  
EMAIL:bronze@bronzecraft.com